

RS-130**Battery-Operated Price Computing Scale****Approvals**

Measurement
Canada
Approved

Standard Features

- Rechargeable battery or 115 VAC operation
- Toggle between lb/kg/oz*
- Eight PLU keys for direct price lookups
- Cash back calculation
- Large stainless steel platter
- Easy-to-read customer display
- In-use cover
- 89 PLUs for indirect price lookups
- Battery charge indicator
- Internal sealed battery included
- NTEP-certified Legal-for-Trade

*Ounces not available in Measurement Canada Approved Model

Specifications**CAPACITY/GRADUATIONS:**

30 lb x 0.01 lb
15 kg x 0.005 kg
480 oz x 0.2 oz

DISPLAY ITEMS:

Weight: 5 digits
Unit price: 5 digits
Total price: 6 digits

ACCURACY:

1/3000

DISPLAY:

LCD, 0.453" (11.5 mm) character

POWER SOURCE:

115/230V $\pm 10\%$, 50/60Hz

BATTERY LIFE:

100+ run hours

WEIGHT:

10 lbs (4.5 kg)

PRESET KEY:

Eight direct price lookups
89 indirect price lookups by
PLU number

ENCLOSURE SIZE:

Platter: 11.8" W x 9.5" D
Overall: 12.3" W x 13.0" D x 4.7" H

OPERATING TEMPERATURE:

32°F to 104°F (0° to 40°C)

WARRANTY

One-year limited warranty

CLASSIFICATION:

NTEP-Certified, 04-067,
Class III 3000d
Measurement Canada Approved:
AM-5565

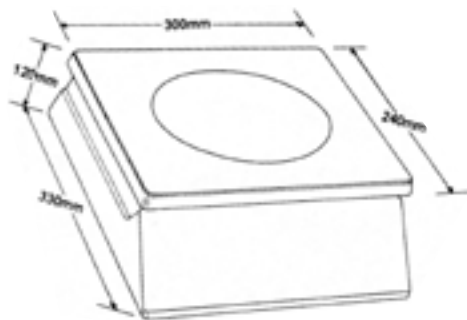
**DIMENSIONS**

Unit	Stainless Steel Platter
13.0 x 4.7" (330 mm x 120 mm)	9.5" x 11.8" (240 mm x 300 mm)

acemex - Electroamerica
BÁSCULAS Y SISTEMAS DE PESAJE ELECTRÓNICOS

Tels: +52 (55) 5393-8878, 5393-9820, 5373-8288

<http://www.acemex.com>
acemex@acemex.com, acepromociones@acepromociones.com